

# Assembly & Installation Instructions

For Intersections Pendants 13-7605 & 13-7610

**A107**

Page 1 of 3

**CAUTION: FAILURE TO INSTALL THIS FIXTURE PROPERLY MAY RESULT IN SERIOUS PERSONAL INJURY OR DEATH AND PROPERTY DAMAGE. We recommend installation by a licensed electrician.**

This product must be installed in accordance with applicable installation code(s), by a person familiar with the construction and operation of the product and the hazards involved.\*

**Caution:** Do not exceed maximum wattage noted on fixture. Use only recommended bulbs with fixture.

## To Attach Fixture Pipes (Figure 1)

### Component Parts

- A Fixture Pipe
- B Fixture

1. Carefully unpack the fixture from the carton.
2. Carefully thread fixture pipe (A), threaded end first, over fixture wires.
3. Apply a drop of the supplied thread locking compound to the internal threads at the top of the fixture (B) and screw stem into fixture, being careful not to twist the wires.

**Note:** Application of the thread locking compound is necessary to prevent the stem from loosening during regular maintenance and cleaning of the fixture. Be certain to apply the compound.

4. See instructions below to complete the installation.

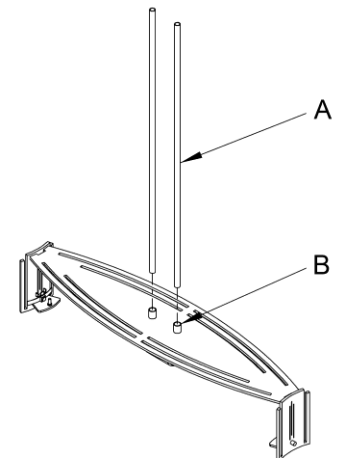

(Figure 1)

## To Assemble Fixture (Figures 2 & 3)

### Component Parts

- |                |                 |
|----------------|-----------------|
| A Fixture Pipe | E Clutch sleeve |
| C Canopy       | F Clutch        |
| D Canopy pipe  | G Set Screw     |

1. Slip the wires from the fixture pipe (A) into and through the canopy pipe (D) up through the canopy (C).
2. Unscrew the clutch (F) from the canopy pipe (D); slide it across the wires and onto the fixture pipe (A). Follow this with the plastic clutch sleeve (E), oriented so the tapered end of the clutch sleeve nests in the clutch (Figure 3).
3. Slide the canopy pipe (D) as far as necessary to give you the total length of the fixture which you desire. Be careful not to scratch the pipe surfaces and to pull excess wire up through the canopy pipe (D). Screw clutch (F) onto canopy pipe (D). There must be a minimum 1-1/2" of inner pipe inside the outer pipe. Hand-tighten the clutch to temporarily hold this adjustment. The clutch is not securely fastened at this point; do not depend on it to hold the fixture.  
**Important:** To ensure full connection strength, be sure the tapered end of the plastic clutch sleeve is oriented toward the clutch (Figure 3).
4. **Stop.** Please see installation instructions below.

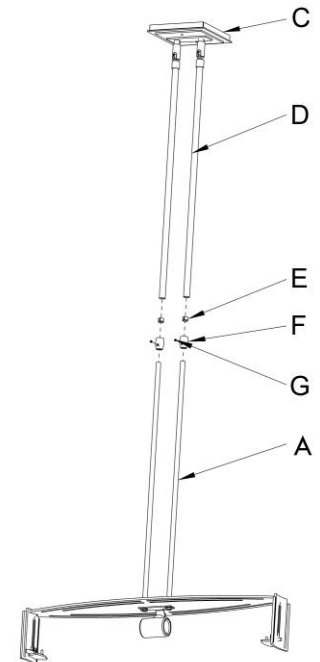

(Figure 2)

(continued)

# Assembly & Installation Instructions

For Intersections Pendants 13-7605 & 13-7610

**A107**

Page 2 of 3

## To Install Fixture (Figure 4)

### Component Parts

- C Canopy
- I Crossbar
- J Threaded stud (2)
- K Ground screw
- L Knurled ball (2)

**Caution: Be sure power is off at the main breaker box prior to installation.**

1. Thread studs (J) through appropriate holes in the crossbar (I) to match hole centers on canopy (C). Move ground screw (K) to another available threaded hole if necessary.
2. Using two machine screws (not provided), fasten the crossbar (I) to the electric box using outer oval slots to orient fixture to desired hanging position.

**Note:** A new electric box comes with screws. When replacing a fixture, retain the existing screws for use with the new fixture.

4. Using suitable wire connectors (not provided) connect fixture wires to supply (white to white and black to black). Connect all ground wires to green ground screw (K).

**Caution:** Make sure wire connectors are twisted on securely, and no bare wire is exposed.

5. Slide fixture canopy (C) with fixture attached, over threaded studs (J) and push firmly to ceiling making sure that no wires are pinched between fixture canopy and ceiling. Fasten with the knurled balls (L). Be sure studs (J) are fully seated in the knurled balls (L).
6. Check fixture for height and level.
7. Once the fixture is fastened to the ceiling, tighten the set screw (Figure 2, G) firmly with hex wrench provided. Only after the set screw (Figure 2, G) is tight should you install the glass.

**Note:** If your fixture has more than one set of pipes or stems in the canopy you will need to level the fixture. While always leaving one clutch firmly locked with the set screw, loosen the other(s). Raise or lower the pipe(s) in the other clutch to obtain plum and level and then tighten the set screw(s).

8. Install light bulbs (not included).
9. Install diffusers; see instructions on next page.
10. Restore electricity at main breaker box.

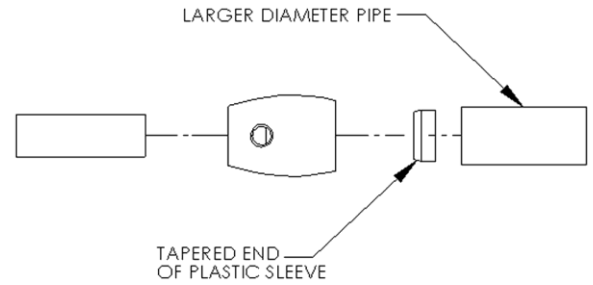

(Figure 3)

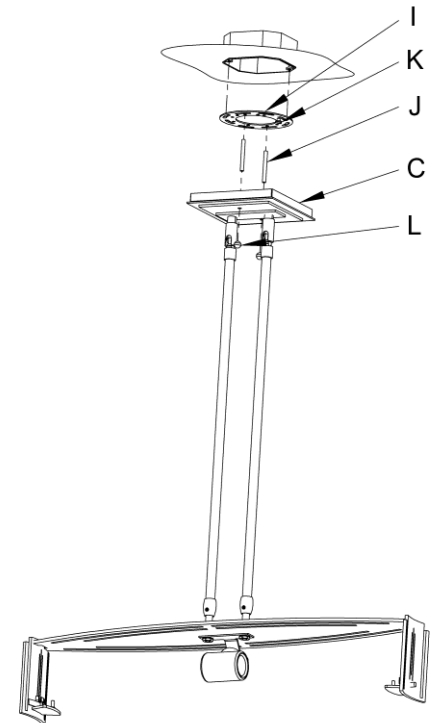

(Figure 4)

# Assembly & Installation Instructions

For Intersections Pendants 13-7605 & 13-7610

**A107**

Page 3 of 3

## To Install Bottom & Side Diffusers (Figure 5)

### Component Parts

L	Knurled ball (2)	P	Bottom Bracket (2)
M	Side Diffuser (2)	Q	Bonded Washer (2)
N	Diffuser Bracket (2)	R	Flat Washer (2)
O	Threaded Studs (2)	S	Bottom Diffuser

1. Slide side diffuser (M) through rectangular holes in top of fixture until it rests inside diffuser bracket (N). Repeat on other side.
2. Align bottom diffuser (S) slots with threaded studs (O) and place diffuser so it rests on bottom brackets (P).
3. Slip flat washer (R) and bonded washer (Q) over threaded studs (O). Rubberized side of washer should contact glass.
4. Thread knurl balls (L) on to threaded studs (O) until snug against bonded washers. Do not to over tighten.

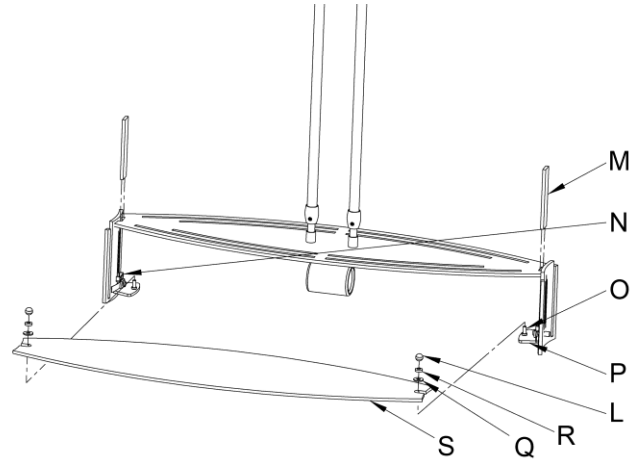

(Figure 5)

## To Install Front & Back Diffusers (Figure 6)

### Component Parts

T	Glass (2)
U	Glass Slot (2)
V	Knob (2)
W	Spring

1. Loosen knob (V) until it stops and push against end of fixture so spring (W) is spaced away from the sides of the fixture, allowing glass (T) to be inserted.
2. Slide glass (T) through glass slots (U) until it rests on ledge.
3. Slide glass left or right until centered.
4. Repeat for second piece of glass.
5. Tighten knob (V) until glass (T) is held firmly in position.

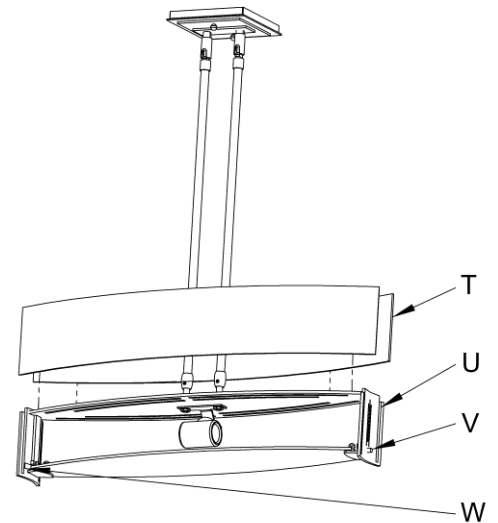

(Figure 6)

*If you need further assistance, or find that you are missing any parts, please contact the dealer from which you purchased this product. We hope you enjoy your fixture!*

\* Hubbardton Forge will not be liable for injury or damage caused by improper installation, lamping or use of this fixture.